



# Boat Trailer Parking Permit Application

Sportsman’s Park - 320 E. Ocean Avenue

Permits may be purchased at the following location at an annual cost of \$53.50 (tax included) and are good for 1 year beginning October 1<sup>st</sup> of each year.

Lantana Town Hall  
500 Greynolds Circle  
Lantana, Florida 33462  
Monday-Friday, 8:30 AM - 4:30 PM

**Make Checks Payable to:  
Town of Lantana**

\*For additional information or questions call (561) 540-5020

Name \_\_\_\_\_ Trailer Tag # \_\_\_\_\_

Address \_\_\_\_\_

City \_\_\_\_\_ State \_\_\_\_\_ Zip \_\_\_\_\_

Day-time contact # \_\_\_\_\_

Email Address \_\_\_\_\_

If you should trade or sell your trailer, you **MUST** remove the permit from the trailer and return it with your new trailer registration in order for it to be re-placed at no charge. Permits are made to break apart upon removal, you do not have to return the permit intact; pieces of the permit will be accepted. **If you cannot produce a current year permit, you are required to purchase a new one at full cost.** Lost permits will also require the purchase of a new permit.

**Permit does not guarantee parking—spaces are on a first-come-first-serve basis.**

I hereby assume the risk associated with the use of the facility and agree to hold the Town of Lantana, its agents, designees, employees, and elected officials free and harmless at all times from and against all claims, liability, expenses, losses, costs, fines, damages or causes of action of every kind and character, including attorney’s fees and costs, whether at trial or appellate levels or otherwise, due to my acts, errors or omissions resulting in bodily injury, including death, or damage to my property or the property of others incident to or in connection with my use of the facility.

I have read and understand the rules and regulations designed for boat trailer parking in the Town of Lantana’s Sportsman’s Park.

Signature \_\_\_\_\_

Date \_\_\_\_\_

**Office Use Only**

Permit # _____	Date Received _____	Receipt # _____
----------------	---------------------	-----------------

bowstand  
(driver side)

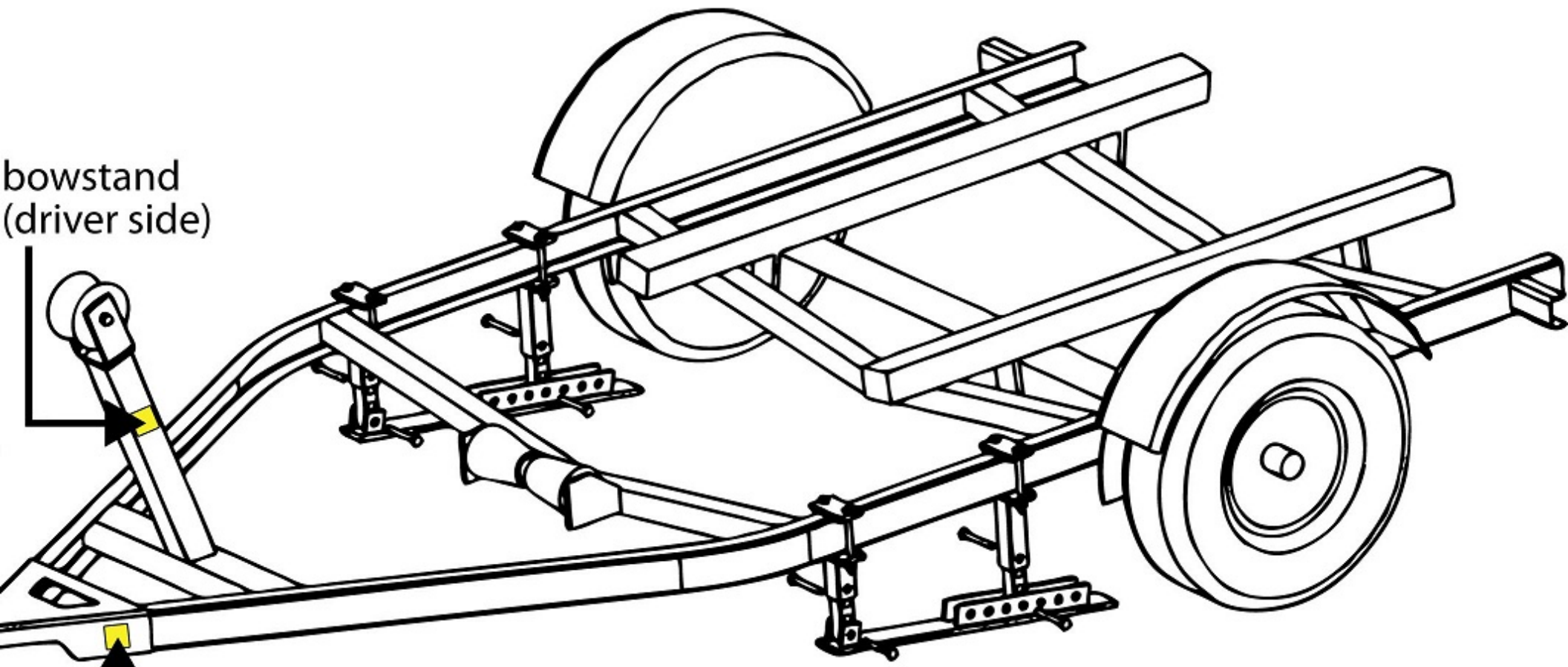

trailer tongue  
(driver side)